



Reichenbach Engineering



# CMOQ-3

## LINE OUTPUT TRANSFORMER

Quadfilar Windings

- Excellent bandwidth
- Choice of lamination stack (high-nickel; 50% high-nickel+50% steel; or steel)
- +18dBm at 20Hz
- Low insertion loss
- Printed circuit pins or lead wires

The CMOQ-3x is wound quad-filar for excellent bandwidth when driven from a moderately low impedance (less than 600Ω recommended). It is available with 80% high-nickel laminations (“H” suffix to the part number); 50% high-nickel + 50% steel (“L”); and steel (“S”) suffixes. It has low insertion loss. It is available with lead wires or printed circuit pins. As applies to all line driving transformers, the driving amplifier should be capable of cleanly delivering the power needed to reach maximum operating level.

Various lamination properties are available each having its own sonic characteristic, from “H” (80% high-nickel) version which is minimally colored, to “S” (steel) at the other end of the spectrum with rich overtones. The “L” version interleaves high-nickel with steel laminations, instead of simply using a 50% alloy. Critical listening tests have proven this to be superior as compared to a 50% alloy. One reason for this is that laminations are heat treated after they are stamped out to relieve stresses in the metal. Silicon steel and nickel heat treat very differently. CineMag’s proprietary annealing processes maximize acoustic performance.

**CMOQ-3H** (High nickel laminations) **CMOQ-3L** (50% hi-nickel interleaved with 50% steel) **CMOQ-3S** (Steel laminations)

Parameter	Conditions	Typ
Turns Ratio		1:1:1:1
Input Impedance, Zi	20Hz to 20kHz, +0dBu Test Circuit 3	637Ω
Voltage Gain	1 kHz, -20 dBu 150Ω input, 39.2K secondary load impedance	-2.8dBu
Distortion (THD+N%) CMOQ-3H Rs=40	1 kHz, +4 dBu Test Circuit 1 20 Hz, +4 dBu Test Circuit 1	0.0002% 0.02%
Max 20 Hz input level CMOQ-3H Rs=40	1.0% THD; Rs=40Ω RL=600 Test Circuit 1	+18dBu
Response, ref 1 kHz	20 Hz -20 dBu Test Circuit 1 20 kHz -20 dBu Test Circuit 1	-0.08 dB +0.15 dB
Phase Shift at 20 Hz Phase Shift at 20 kHz CMOQ-3H Rs=600	Referenced to source generator Test Circuit 1	+0.5° -2.4°
CMRR Rs=40	60 Hz Test Circuit 2 per IEE Std 389 ¶19 1 kHz Test Circuit 2 per IEE Std 389 ¶19	104 dB 98 dB
Output CMRR	60Hz Test Circuit 2 1kHz	112dB 118dB
Operating Temp Range	Operation and storage	0° C Min 70° C Max
Max Soldering Temp (p.c. pins)	5 Seconds	270°C Max

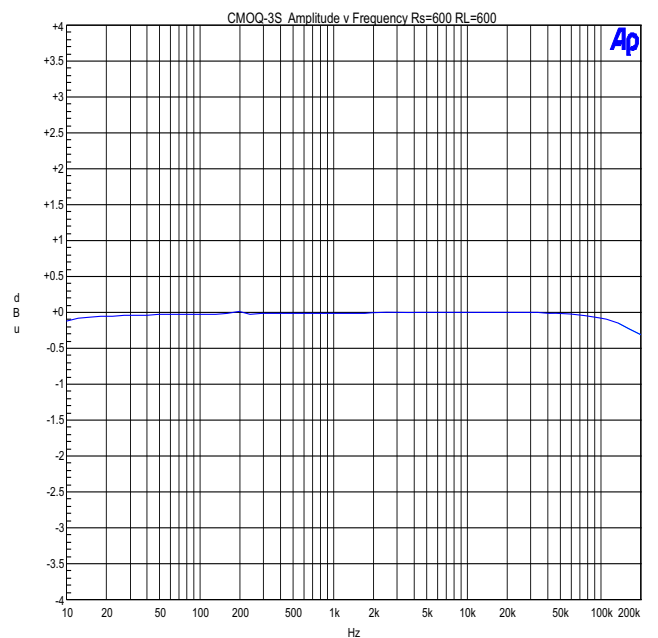
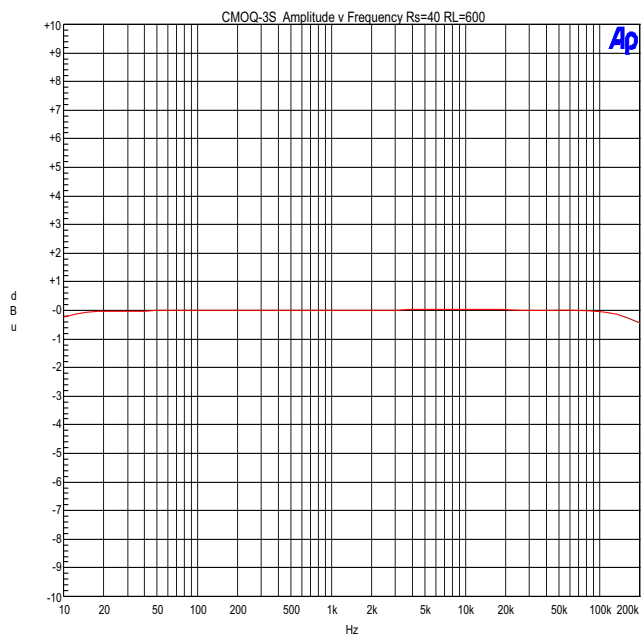
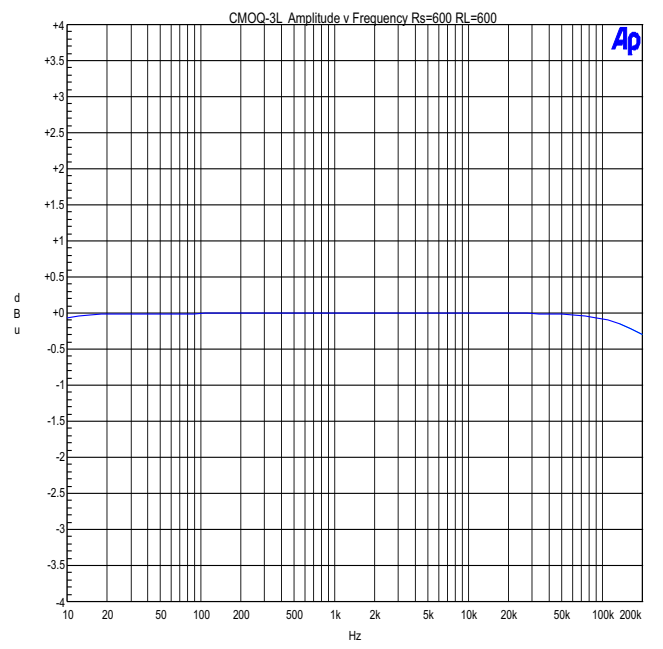
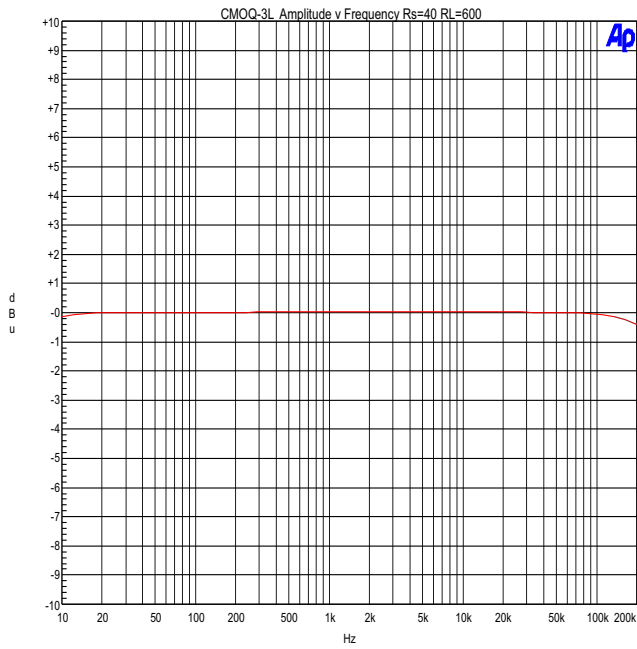
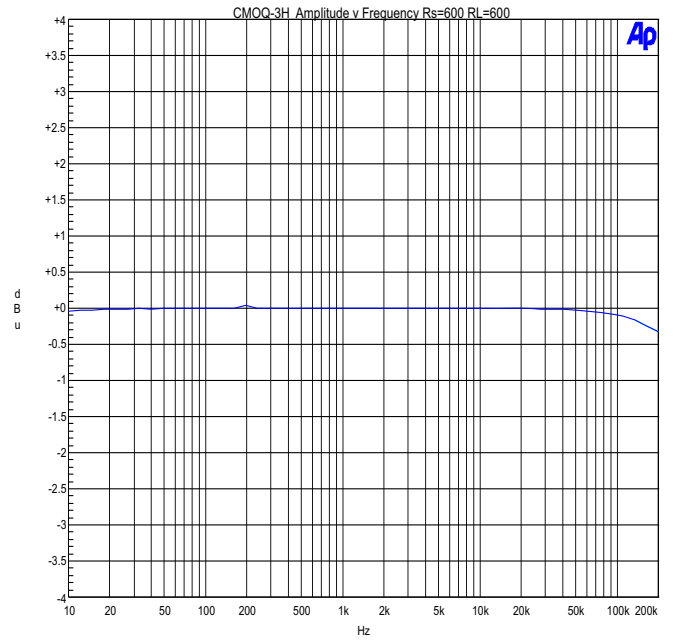
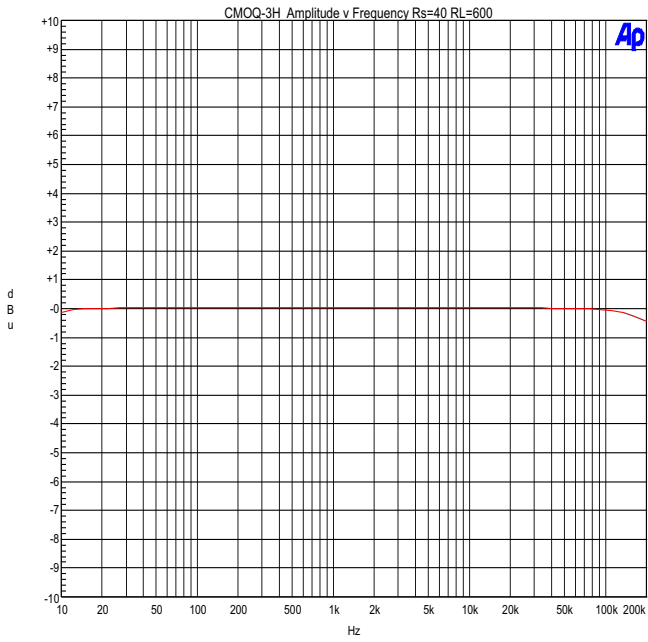

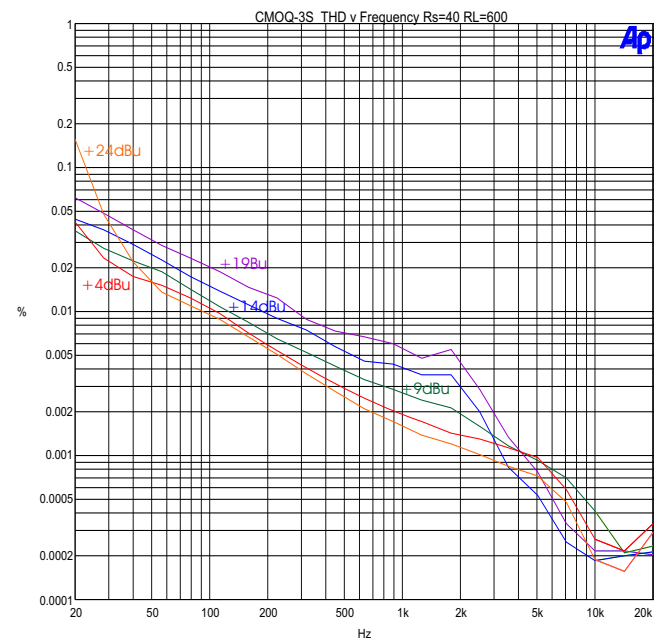
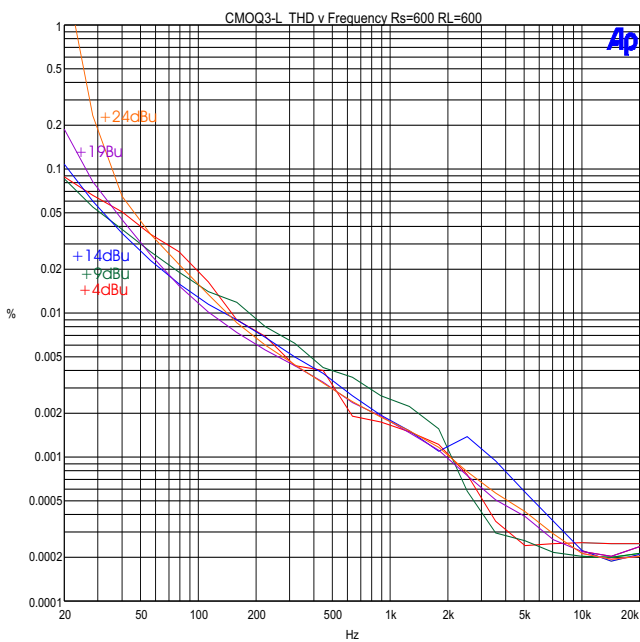
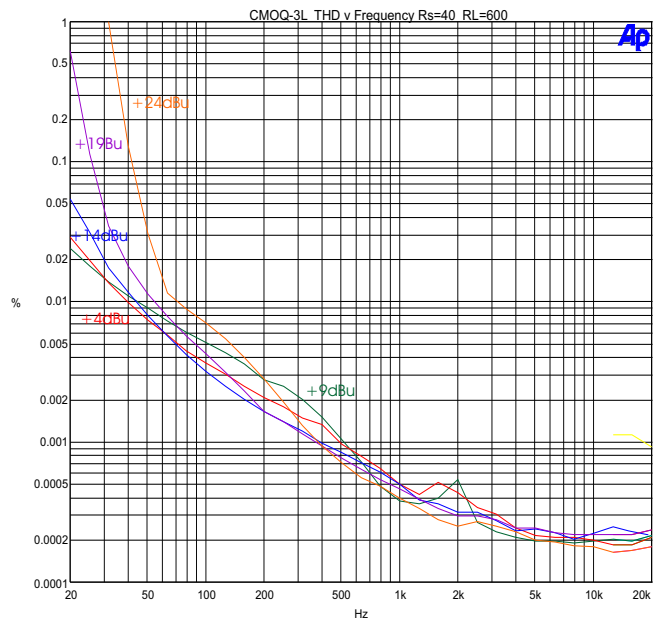
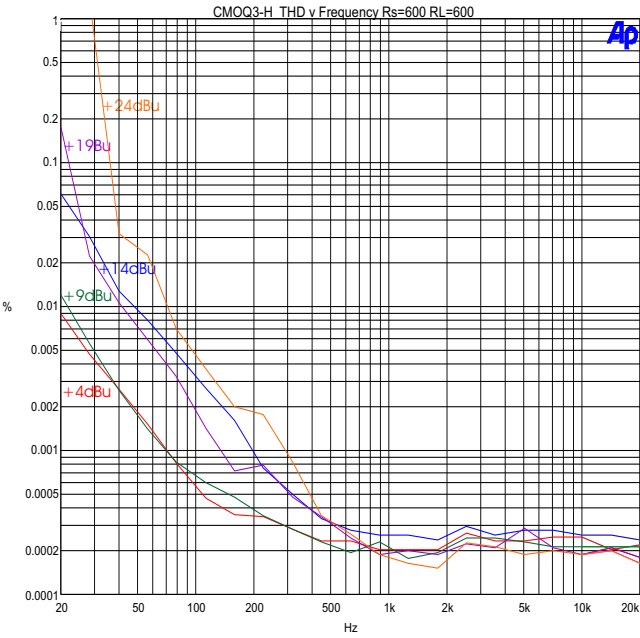
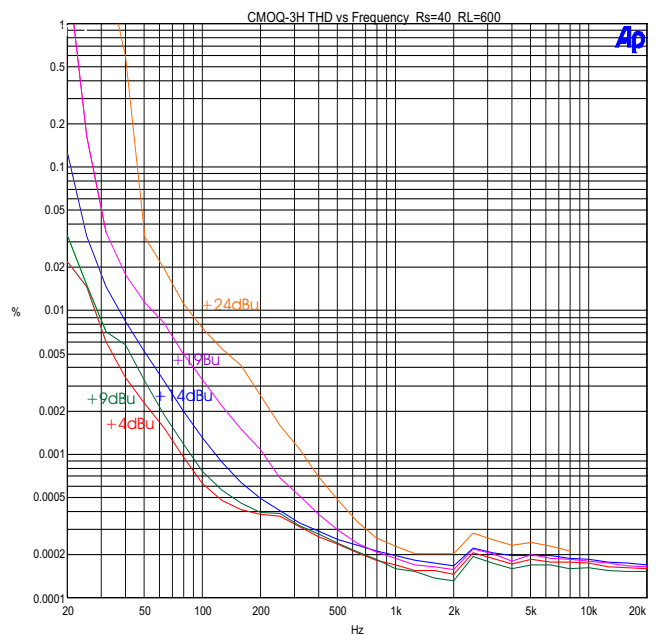
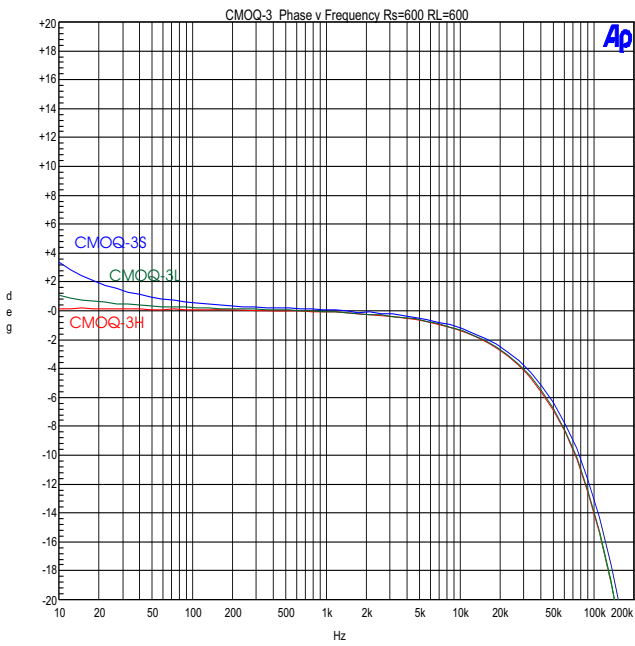

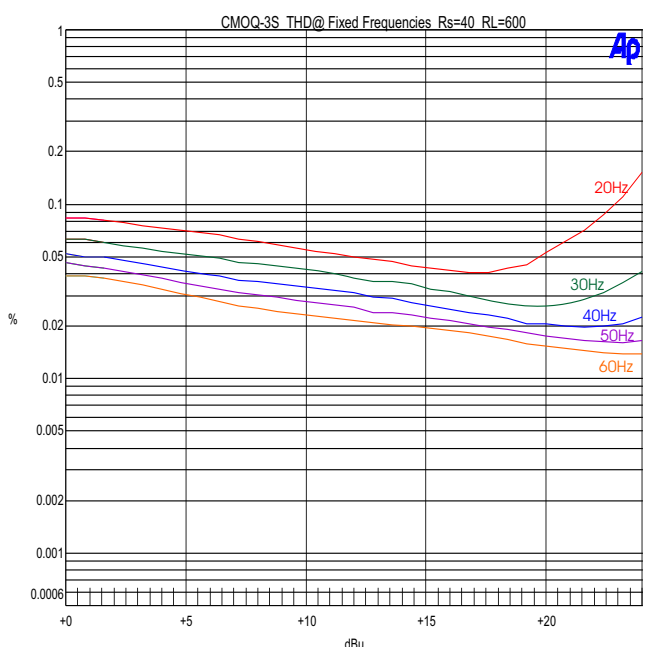
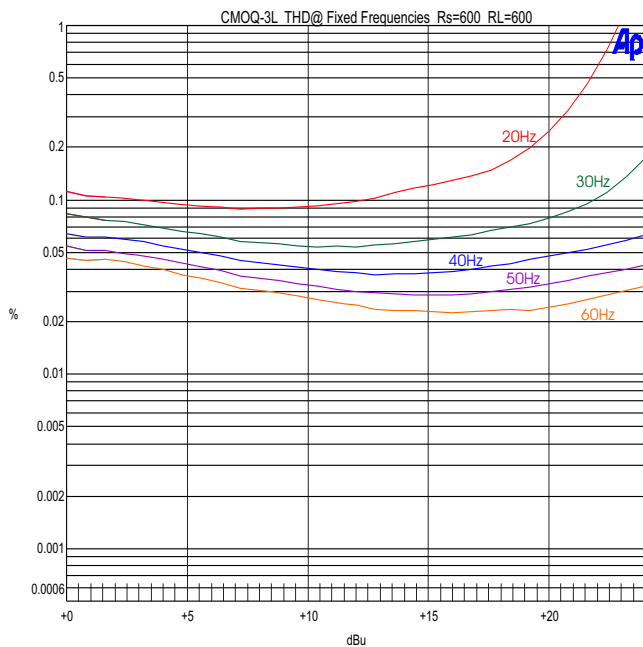
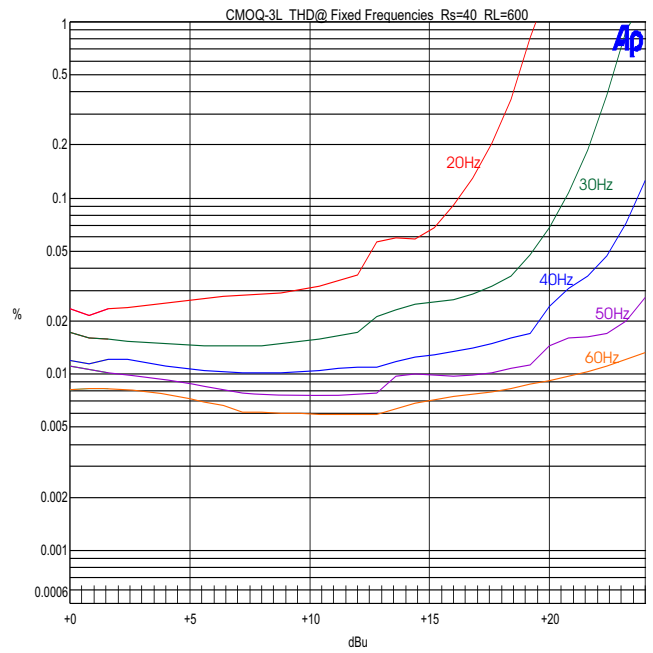
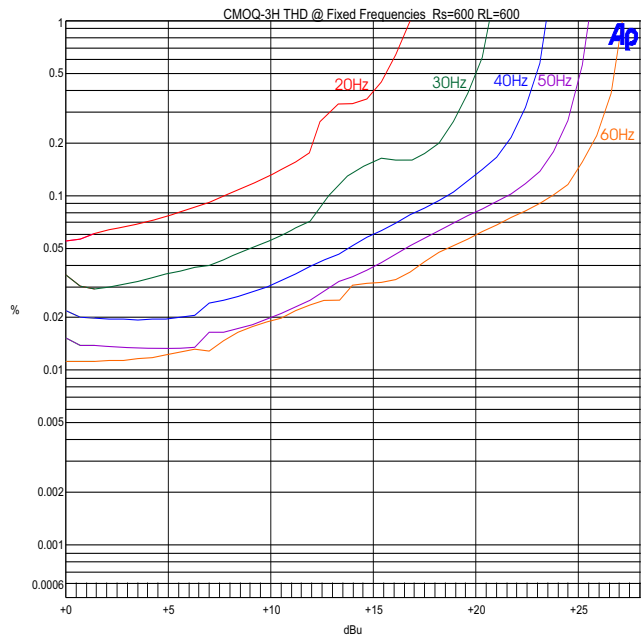
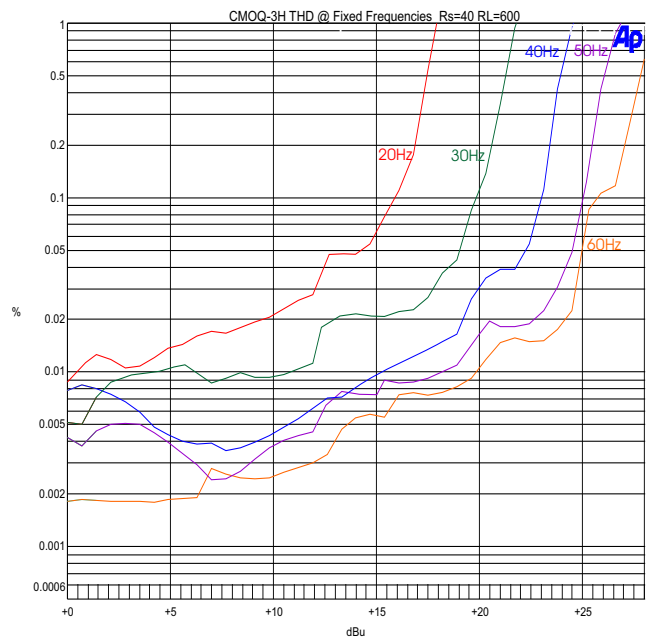
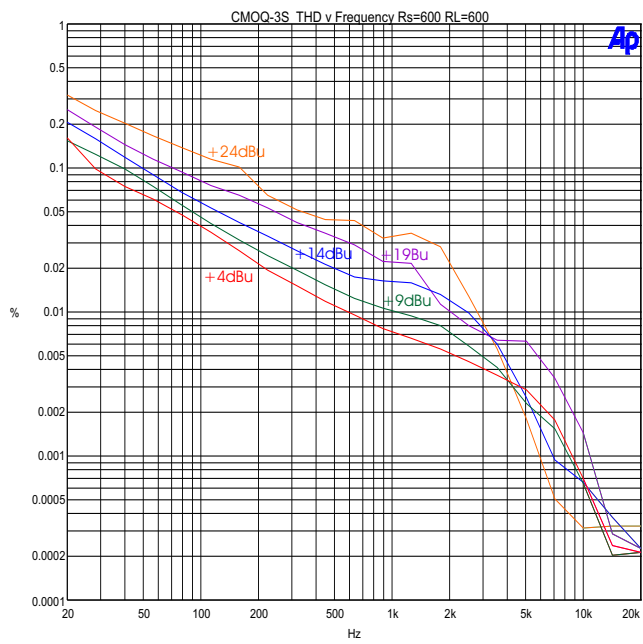

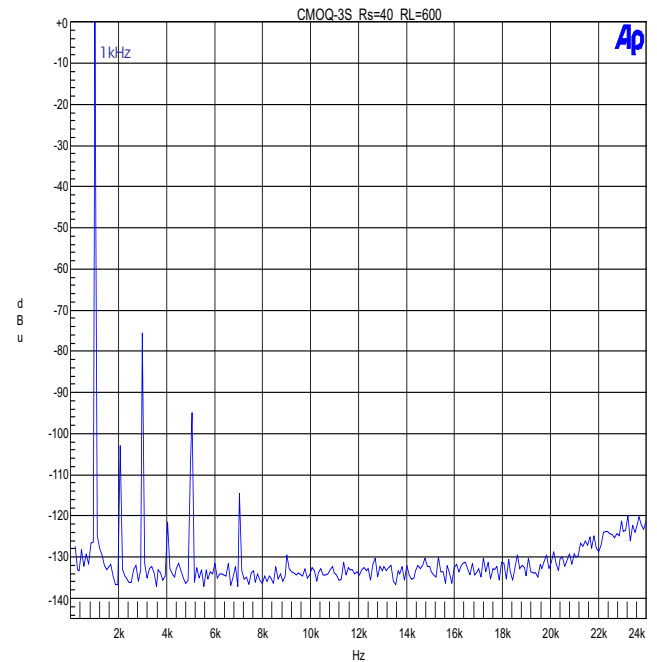
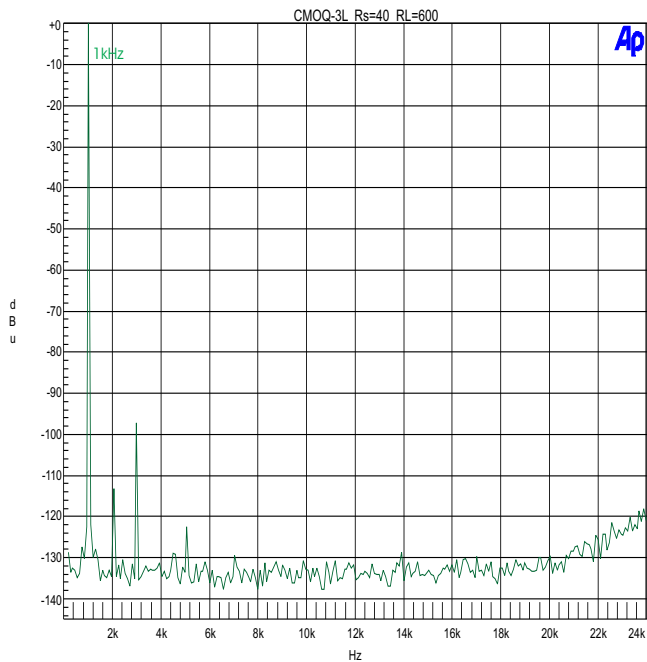
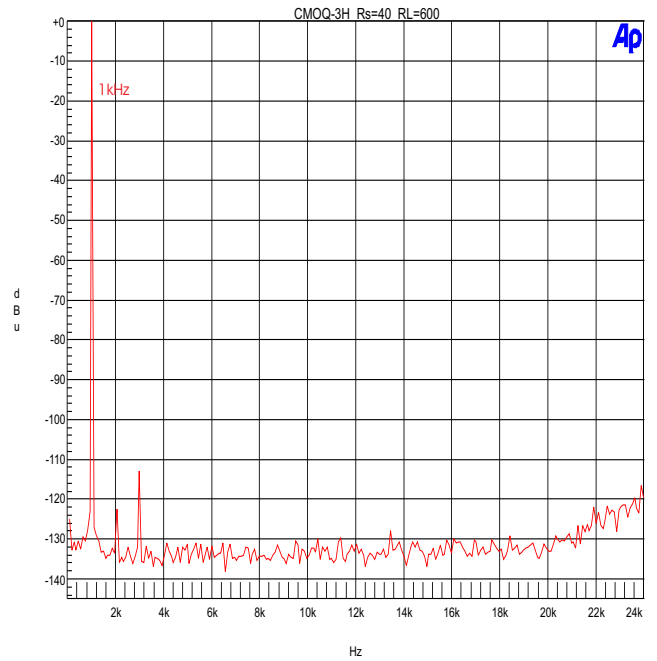
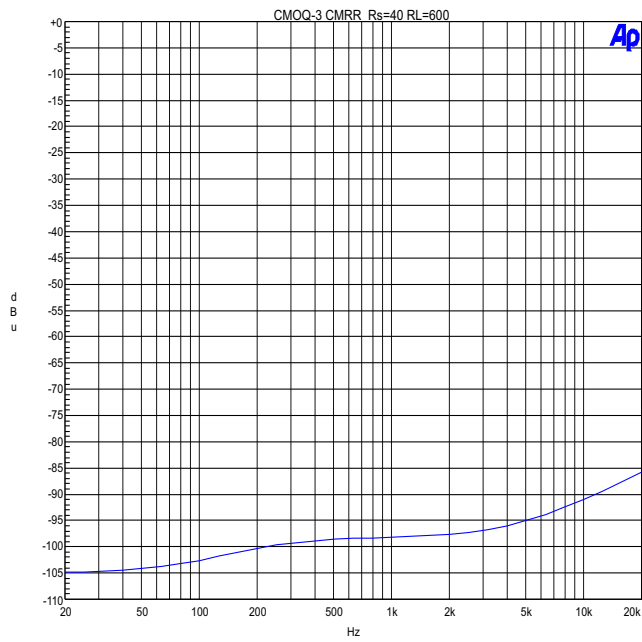
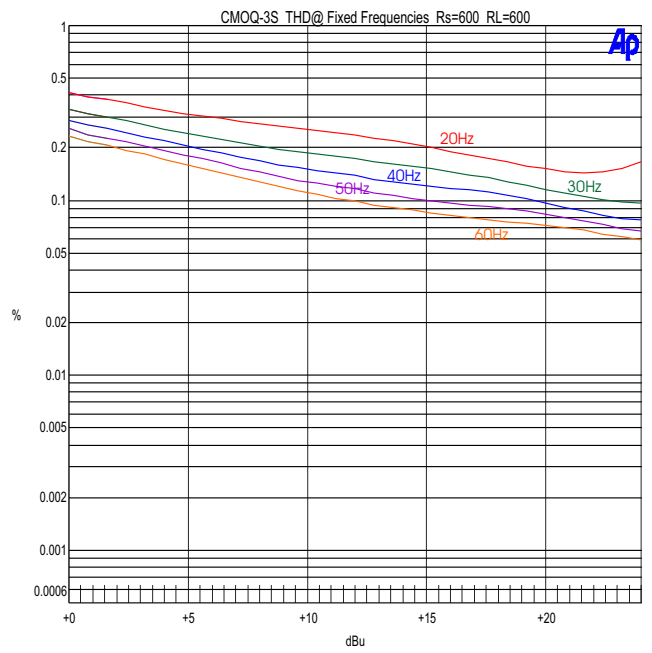
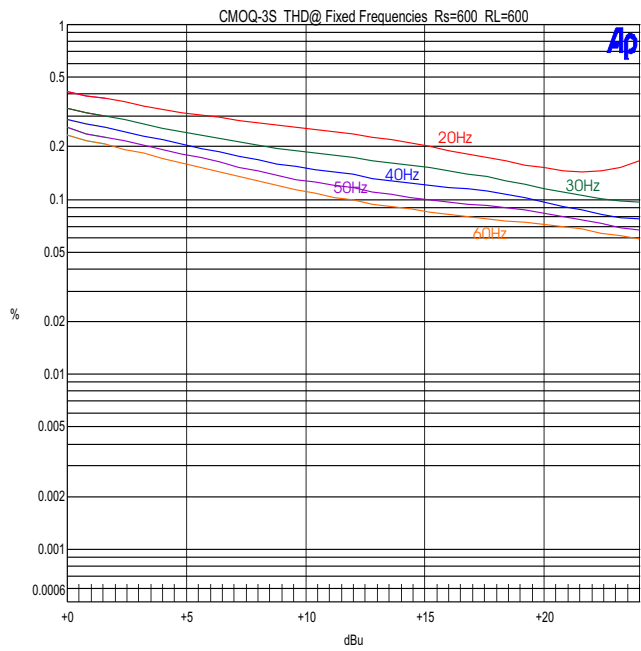



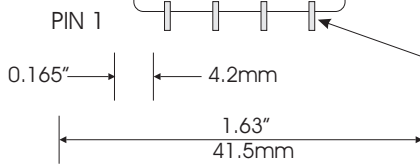
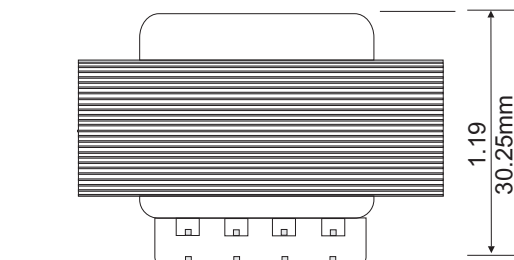
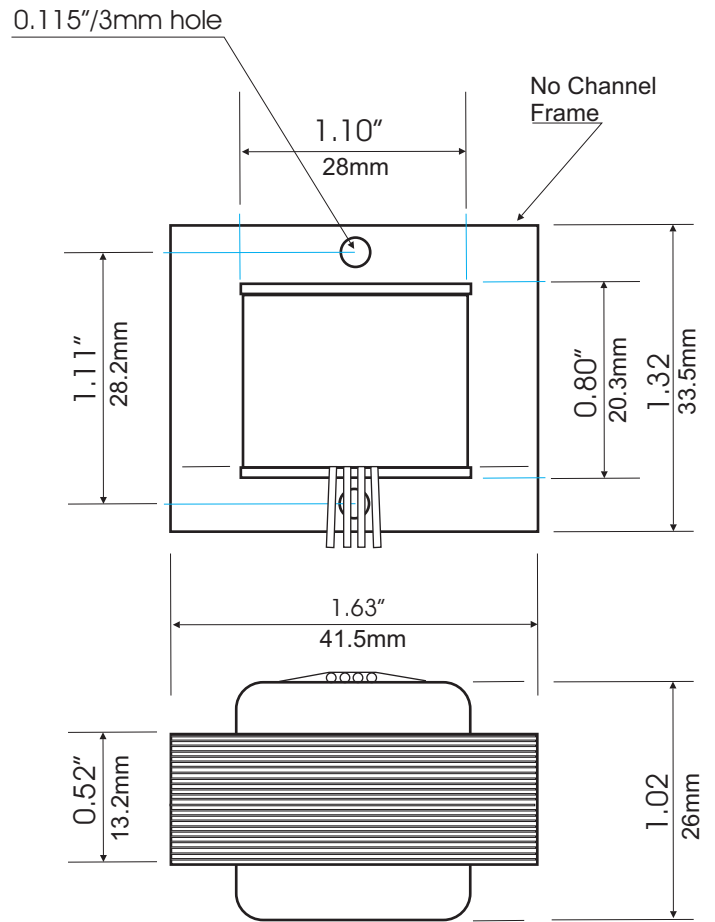
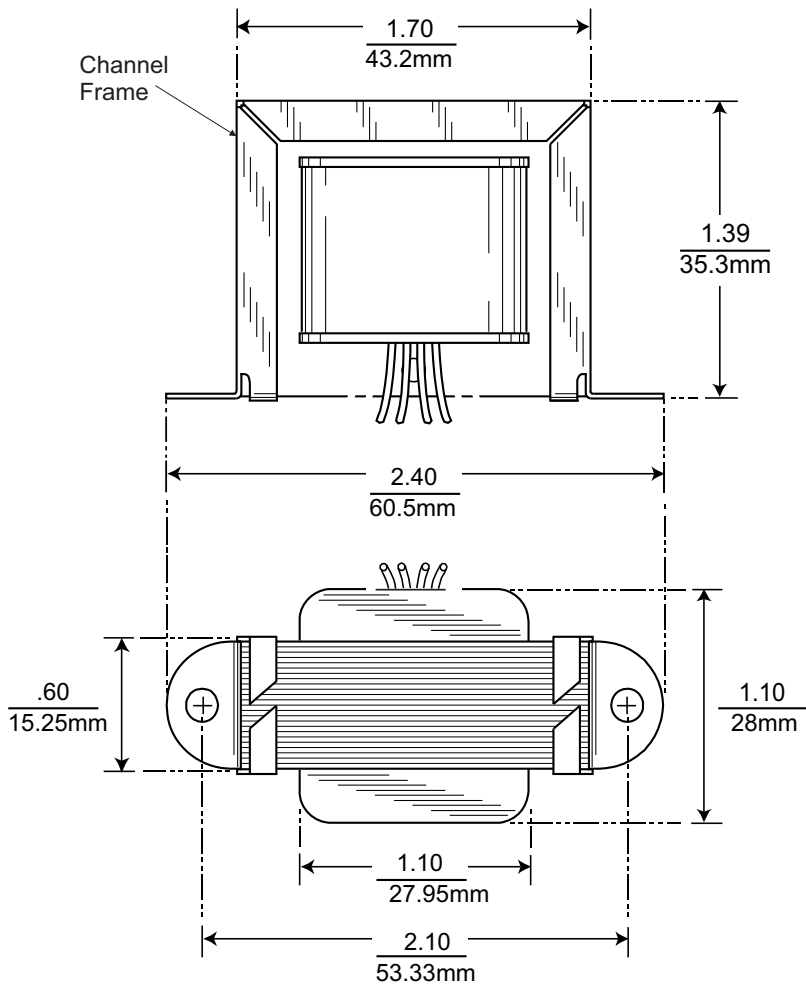

Printed Circuit Pins  
0.026"x0.026"  
0.66mm x 0.66mm

